

# Grinding spindle MSP\_S12o\_Z7

**CDVS**  
TECHNOLOGY  
GROUP

**WMZ**  
MOTORSPINDELN

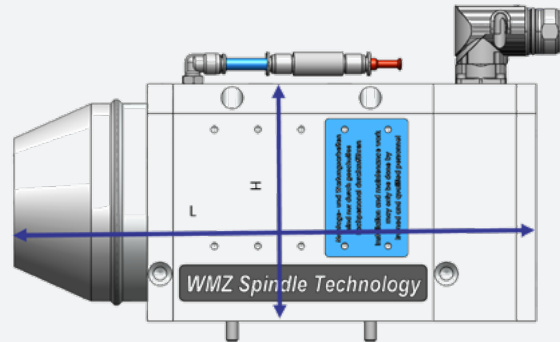
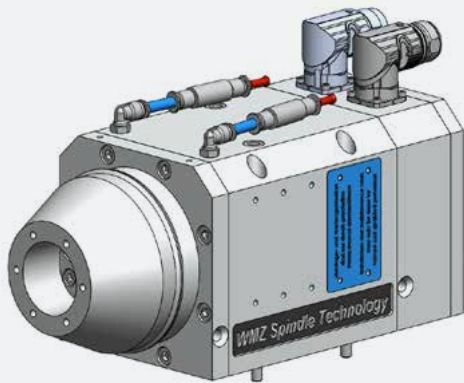

<b>Article number</b>				<b>ZN05-076-00K</b>
<b>Maximum speed</b>			[1/min]	12.500
<b>Housing</b>	Spindle with slide-in housing, closed cooling		[mm]	265
	Length of spindle [L]		[mm]	120 x 120
<b>Bearing</b>	Chassis [H]		< >	< >
	Arrangement	Bearing front	[mm]	55
	Ø Inside	Rear bearing	[mm]	35
<b>Lubrication</b>		Permanent grease lubrication		
	Type	GS34		
<b>Motor</b>	Lubricant	1FE1041-6WM10		
	Designation	Rated speed	[1/min]	12.500
	Y	Torque S1 / S6-40%	[Nm]	4,5 / 6
		Power S1 / S6-40%	[kW]	6 / 8
		synchronous		
	Motor type	SIN 18/36 A		
	Inverter	Water+glycol		
<b>Sealing</b>	Cooling medium	Labyrinth seal		
	Version	air-locked		
<b>Interface</b>		Mounting hole D 42		
<b>Rotating union</b>	Type	without		
<b>Encoder</b>	Version	Heidenhain ERM2400		
	Version	1200		
<b>Options</b>	Number of increments			
	Temperature sensor			
	Vibration sensor			
	Body sound sensor in the spindle			
	Cylinder mount			
	Cylindrical insertion chassis			

## Werkzeugmaschinenbau Ziegenhain GmbH

Am Entenfang 24  
D-34613 Schwalmstadt-Ziegenhain

T +49 6691 9461-0  
F +49 6691 9461-20

## Service-Hotline

for Assemblies T +49 6691 9461-44  
for Machines T +49 6691 9461-38